

(No Model.)

H. C. PAINE.

LATHE FOR TURNING IRREGULAR FORMS.

No. 264,332.

Patented Sept. 12, 1882.

Fig. 1.

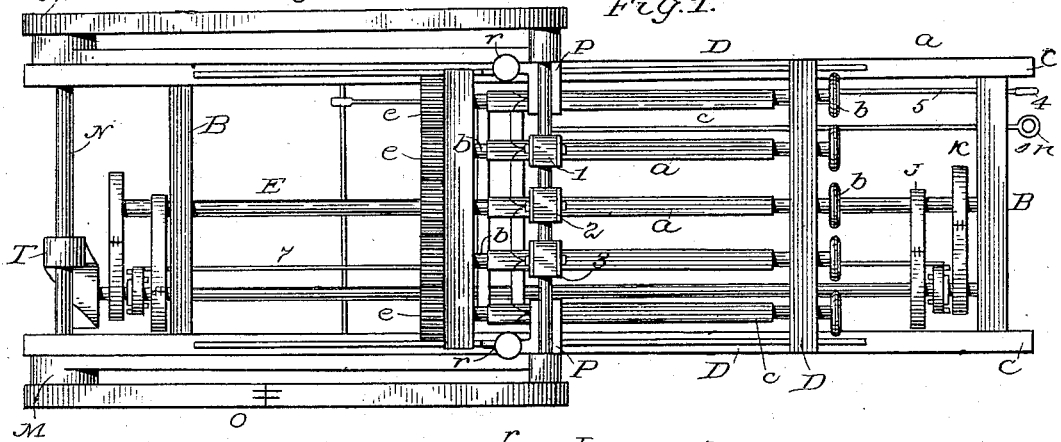

Fig. 2.

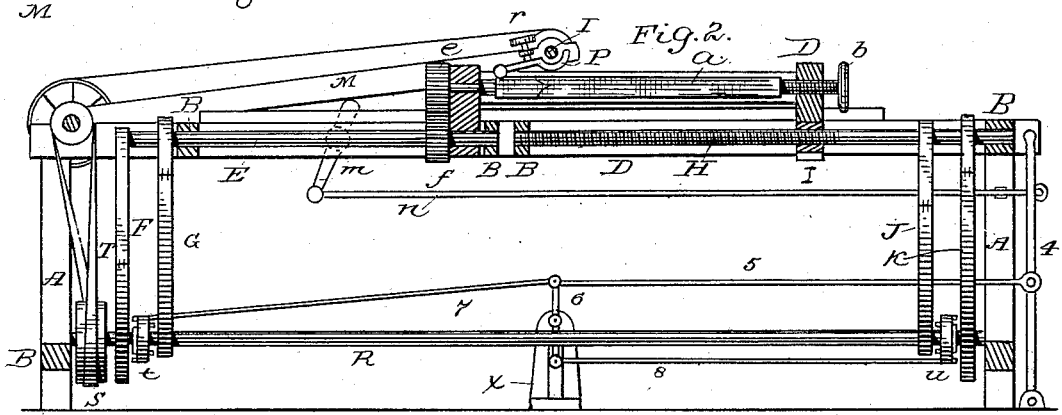

Fig. 3.

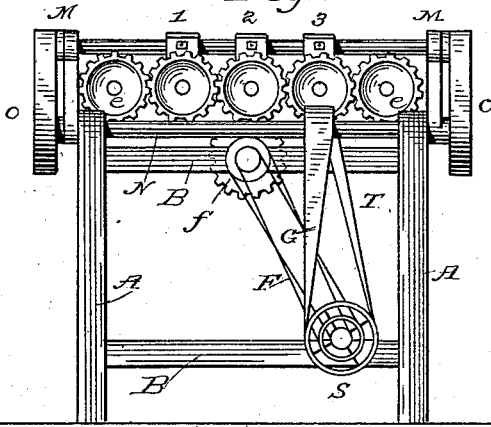
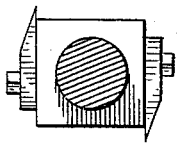

Fig. 4.



witnesses:
Valentino Maldon
F. L. Middleton

Inventor
Henry C. Paine
 by *Ellis Spear*
 Atty

UNITED STATES PATENT OFFICE.

HOLLIS C. PAINE, OF LYNN, MASSACHUSETTS, ASSIGNOR OF ONE-FOURTH
TO WILLIAM F. HUTCHINSON, OF SAME PLACE.

LATHE FOR TURNING IRREGULAR FORMS.

SPECIFICATION forming part of Letters Patent No. 264,332, dated September 12, 1882.

Application filed September 16, 1881. (No model.)

To all whom it may concern:

Be it known that I, HOLLIS C. PAINE, a citizen of the United States, residing at Lynn, in the county of Essex and Commonwealth of Massachusetts, have invented certain new and useful Improvements in Lathes for Turning Irregular Forms, of which the following, in connection with the accompanying drawings, is a specification.

This invention relates to that class of lathes in which a rotary cutter-head operates, in conjunction with a follower and pattern, for manufacturing articles of irregular shape or form; and the objects of my invention are to afford facilities whereby several articles may be turned simultaneously all of one shape and without superfluous movements in machinery.

The invention consists in combining, with means for operating and guiding the cutters and revolving the spindles of a pattern-lathe, means for varying the speed of the spindles and of the traveling carriage.

In the accompanying drawings, Figure 1 is a plan view of the entire machine. Fig. 2 is a side elevation made partly in section. Fig. 3 is an end elevation of the machine. Fig. 4 is an end elevation of the cutter-head.

The legs A, cross-bars B, and side bars, C, constitute the main frame of the machine. The side bars, C, are provided with suitable tracks, *a*, Fig. 1, along which the rectangular carriage D D D D is allowed to slide. Said carriage is provided with a system (in this case) of five live spindles, *b*, adapted to hold the patterns *c* and stocks *d*. Connected with said spindles is a system (in this case) of five gear-wheels, *e*, by means of which motion is transmitted from the gear-wheel *f* to each of said spindles. The said gear *f* is arranged to slide along the shaft E, and is made to revolve therewith by means of the usual spline and key contrivance, the shaft itself being revolved by means of the belts F G, referred to hereinafter. The spindle-carriage D is driven in one direction by means of the screw-shaft H, which is grasped by a split nut, I. Said nut being opened the carriage may be forced back by hand whenever occasion requires. Motion is imparted to the shaft H through suitable belts, J K, also referred to hereinafter.

The cutter-heads 1 2 3, for shaping the stock,

being constructed in the usual manner, are fixed upon the shaft L, as shown in Fig. 3. At each end of the shaft is a follower, *p*, Fig. 2, having a shank portion attached to the arm M, and a semicircular portion, which partly surrounds the shaft L, as shown. Said followers are made adjustable by means of screws *r*, whereby the followers may be elevated or depressed, so as to carry the line of contact between the followers and patterns into a higher or lower horizontal plane, but in nearly the same vertical plane with that between the cutter-heads and the finished stock. In this manner the size of the articles turned may be increased or decreased diametrically without regard to the size of the pattern. The same result may be accomplished by having the follower stationary and making the pattern-holding spindles adjustable vertically in reference to the follower. Said shaft L revolves in the front ends of the lever-arms M M, which in turn are arranged to turn or oscillate on the driving-shaft N. The shaft L is made to revolve (carrying the cutter-heads 1 2 3) by the endless belts O O, arranged as shown. While adjusting or removing the stock the cutter-heads are elevated by means of the lever *m* and push-rod *n*. (See Fig. 2.) It must now be evident that when the revolving cutters are allowed to come in contact with the stock, as shown in said Fig. 2, their effect is to eat into the stock *d* till the edge or surface of the followers *p* come in contact with the patterns *c c*. The spindle-carriage is then advanced while the spindles carrying the stock and patterns are revolved. The followers in the meantime conforming to the shape of the patterns, raise and lower the cutter-heads in such a manner as to give the finished stock a shape exactly like the patterns *c c*.

The machine represented in the drawings is designed more particularly for making wheel-spokes, in turning which I have found by experience that the best results are obtained by running the spindles and the spindle-carriages at a low speed while the cutters are on the throat part of the spoke and at a higher speed while the cutters are on the round part thereof. I am also persuaded that this feature will be found equally useful in turning other articles. In order therefore to vary the speed of the

shaft E and screw-rod H', I use the clutch mechanism shown in Fig. 2. A longitudinal shaft, R, runs in bearings in the ends of the main frame of the machine, motion being imparted to it by a belt, T, from a pulley on the driving-shaft, to a fixed pulley, S, keyed on the said shaft R. Near each end of this shaft is a pair of loose pulleys, over which the belts F G, connected to pulleys on shaft E, and the belts J K, connected to pulleys on the screw-shaft H, respectively pass. The pulleys on the shaft R are of such diameter that the belts F and K and the belts G and J run at the same relative speed, though at a different actual rate. The pulleys being loose, I employ a peculiar clutch mechanism for fixing them on the shaft and for transferring the driving-power, and thus changing the rate of speed. Between each pair of pulleys is a wheel (marked respectively *t* and *u*) splined to the shaft R, but free to move longitudinally thereon. Both wheels carry on both faces projecting pins adapted to engage with recesses or projections in either of the pair of loose pulleys. A lever, 6, is pivoted in a standard, X, and has two

connecting-rods, 7 8, attached respectively to the clutch-wheels *t* and *u*. A rod, 5, having a hand-lever, 4, is employed for operating the pivoted lever, and the clutches may be made at pleasure to engage with the pulleys F and K, or with the pulleys G and J, according to the rate of speed desired.

What I claim as new, and desire to secure by Letters Patent, is—

In a pattern-lathe, a carriage having one or more spindles mounted thereon and operated by a screw-shaft, a shaft, E, by which rotary motion is given the said spindles, in combination with a shaft carrying a series of loose pulleys and a clutch mechanism, whereby the actual speed of the traveling carriage and of the rotating stocks may be changed without altering their relative velocity.

In testimony whereof I have signed this specification in presence of two witnesses.

HOLLIS C. PAINE.

Witnesses:

C. B. TUTTLE,
THOS. NICHOLS.